

ABS lifting station Piranhamat 701

Flood-proof lifting station for the automatic pumping of sewage from areas below the backwash level in accordance with EN 12050-1. The Piranhamat 701 is used for the reliable and economic discharge of wastewater under pressure using small diameter discharge lines. Suitable for new installations or for renovation of old buildings.



Features

- Ready for installation; robust, compact tank, suitable for single-family houses.
- Easily transported and fitted. Compact dimensions allow passage through a standard door opening.
- Fitted with ABS Piranha submersible grinder pump for problem-free pumping of sewage and wastewater containing faecal matter in pipe lines from 1¼" diameter (DN 32).
- Nine horizontal inlet ports (6 x DN 100, 3 x DN 40) and four vertical (2 x DN 70, 2 x DN 40). One DN 70 port is needed as a vent line. DN 40 is suitable for the connection of a hand membrane pump.
- Pumps high head up to 30 m. Most suitable for applications with minimum head of 8 m.
- Cast iron discharge outlet with threaded flange G 1¼".
- Shredding system consisting of a spiral bottom plate containing a stationary cutter ring with cutting edges and a shredding rotor located below the impeller, reduces the medium for optimum blockage-free running.
- Shaft sealing between motor and hydraulic section by means of a single mechanical seal of silicon carbide, independent of direction of rotation, resistant to temperature shock and to dry running. Motor side: lip seal, oil lubricated.
- Motor shaft is mounted in lubricated-for-life, maintenance-free ball bearings.
- Maximum allowable temperature of the medium is 40 °C; or up to 60 °C for a maximum of five minutes.

Materials

Description	Material
Tank	Polyethylene (PE)
Motor Housing	Cast iron EN-GJL-250
Rotor Shaft	Stainless steel 1.4021 (AISI 420)
Volute	Cast iron EN-GJL-250
Impeller	Cast iron EN-GJL-250
Bottom Plate	Cast iron EN-GJL-250
Fasteners	Stainless steel 1.4401 (AISI 316)

Tank

Synthetic, corrosion-resistant, gas- and odour-tight tank, in accordance with EN 12050-1. Supplied as standard with pump and control panel with automatic level control and alarm. Capacity: 70 litres

Motor

Water pressure sealed, squirrel cage 2-pole induction motor, with double shaft seals and oil chamber. Electronic monitoring of stator temperature and overcurrent. Insulation: Class F for 155 °C Protection type: IP 68

Installation

Attention to the backwash level is of vital importance for effective dewatering. All outflow points located below the backwash level must be protected against back flow according to standard EN 12056. A pump sump should be provided for dewatering of the room itself.

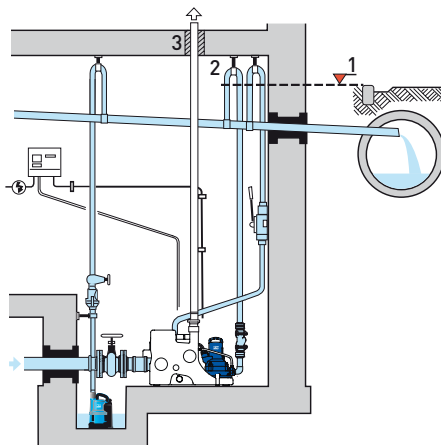

1. Backwash level
2. Backwash loop with base above the backwash level
3. External ventilation pipe

Performance Curves

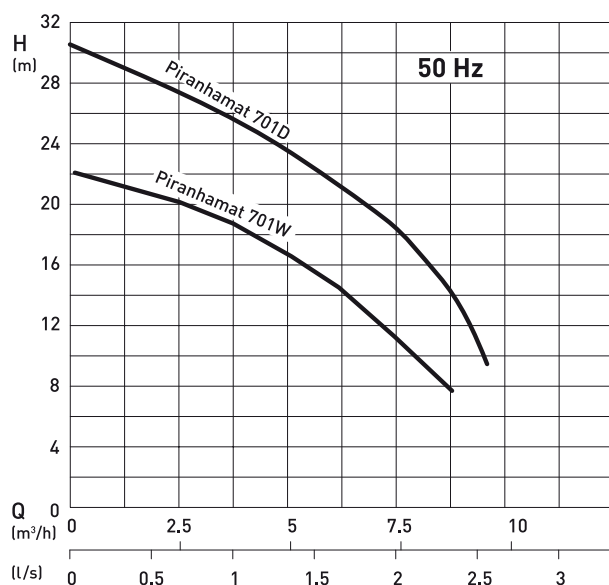

H = Total Head; Q = Discharge Volume
Curves to ISO 9906 (60 Hz available on request)

Technical Data

Piranhamat	701 W	701 D
Motor power* (kW)	P ₁ = 2.3 P ₂ = 1.7	P ₁ = 2.3 P ₂ = 1.7
Speed (r/min)	2900	2900
Rated voltage (V)	220-240 1~	400 3~
Rated current (A)	7.0	4.0
Cable type (S1BN8-F)	4G1.5	4G1.5
Cable length** (m)	4.0	4.0
Weight*** (kg)	58	58

* P1 = Power at mains, P2 = Power at motor shaft
 ** Control Unit fitted with 1.5 m cable and plug.
 *** Additional weight of hand membrane pump = 13 kg.

Tank Dimensions (mm)

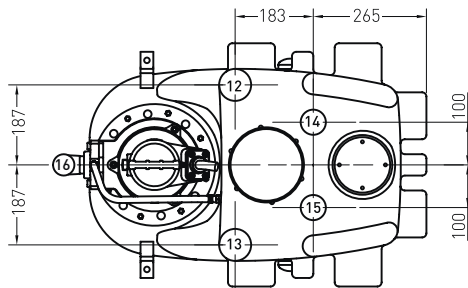
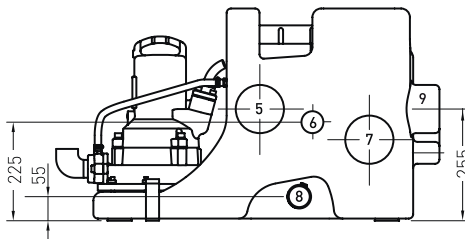
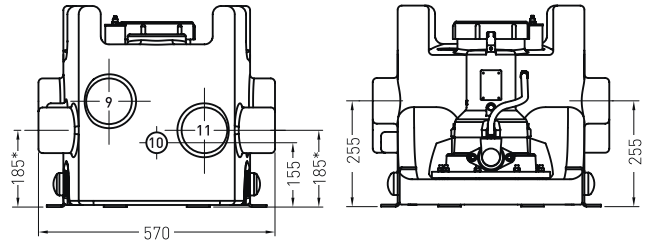
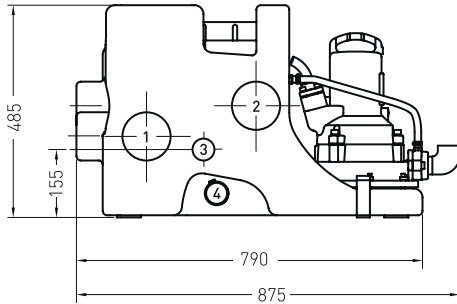

Connections

- | | |
|-------------------|-------------------------------------|
| 1. Inflow DN 100* | 9. Inflow DN 100 |
| 2. Inflow DN 100 | 10. Inflow DN 40 |
| 3. Inflow DN 40 | 11. Inflow DN 100* |
| 4. Drain DN 40 | 12. Inflow/Vent DN 70 |
| 5. Inflow DN 100 | 13. Inflow/Vent DN 70 |
| 6. Inflow DN 40 | 14. Inflow/Hand membrane pump DN 40 |
| 7. Inflow DN 100* | 15. Level control DN 40 |
| 8. Drain DN 40 | 16. Discharge line G 1 1/4" |

* not suitable for use under EN 12056

Note:

Rooms for sewage lifting stations must be large enough that a working area of at least 60 cm width or height is available around all parts which have to be operated or maintained. A pump sump should be provided for dewatering of the room itself.

Inlet Diameters

Ø	(mm)
DN 70	+0.2 ø75 -1.0
DN 100	+0.3 ø110 -1.0
DN 150	+0.4 ø160 -1.5

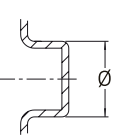

Accessories

Description	Size	Part no.
Hand Membrane Pump for separate wall fixing; with built-in, non-return valve	G 1 1/2"	14990028
Wall-fixing Kit for hand membrane pump		62660036
Gate Valve (brass) with internal thread	G 1 1/4"	14040005
Non-return Valve ball valve, cast iron EN-GJL-250	G 1 1/4"	61400525